

## Grooved Resilient Swing Check Valve (H84X), UL/FM Approved

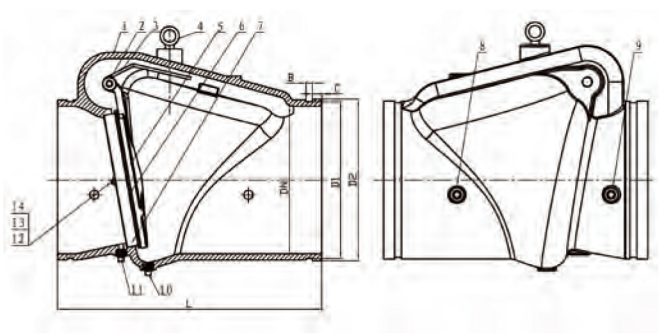

- Connection Ends: Groove to AWWA C606
- Working Pressure: 300PSI  
200PSI and 250PSI available upon request
- Temperature Range: 0°C- 80°C
- Coating: Fusion Bonded Epoxy Coating in accordance with ANSI/AWWA C550 or painting upon request



### MATERIAL SPECIFICATION

Part No.	Part	Standard Specification	Options
1	Valve Body	ASTM A536, 65-45-12	
2	Hinge Pin	AISI 420	
3	Spring	AISI 304	AISI 316
4	Eye Bolt	Carbon Steel Zinc Plated	
5	Disc	DN50-100 AISI 304 DN150-300 ASTM A536, 65-45-12	AISI 304
6	Disc Sealing Ring	EPDM	
7	Seat Ring	ASTM B62 C83600 (Pressed Fit)	AISI 304, AISI 316 Pressed Fit or Threaded
8	Plug	Malleable Iron Galvanized	Bronze ASTM B584
9	Plug	Malleable Iron Galvanized	Bronze ASTM B584
10	Plug	Malleable Iron Galvanized	Bronze ASTM B584
11	Plug	Malleable Iron Galvanized	Bronze ASTM B584
12	Bolt	AISI 304	AISI 316
13	Washer	AISI 304	AISI 316
14	Nut	AISI 304	AISI 316

Note: For special material request other than standard specification, please indicate clearly on the inquiry or order list.

DN		Dimensions(mm)				
Inch	mm	L	D1	D2	B	C
2"	50	171	57.15	60.3	7.93	15.88
2.5"	65	184	69.09	73	7.93	15.88
3"	80	197	84.94	88.9	7.93	15.88
4"	100	210	110.08	114.3	9.53	15.88
5"	125	248	137.03	141.3	9.53	15.88
6"	150	324	163.96	168.3	9.53	15.88
8"	200	371	214.4	219.1	11.13	19.05
10"	250	457	268.28	273	12.7	19.05
12"	300	535	318.29	323.9	12.7	19.05