

# Gate Valve-S12

Investment casting body

Pressure Rating: 200 PSI

Working Temperature: -25 ~180°C

Medium: Water, Oil, Gas

Material: 304, 316, 1.4308, 1.4408, CF8, CF8M

Thread: ASME B1.20.1 BS21.DIN2999/259,

ISO228-1,JIS B 0203,ISO7/1

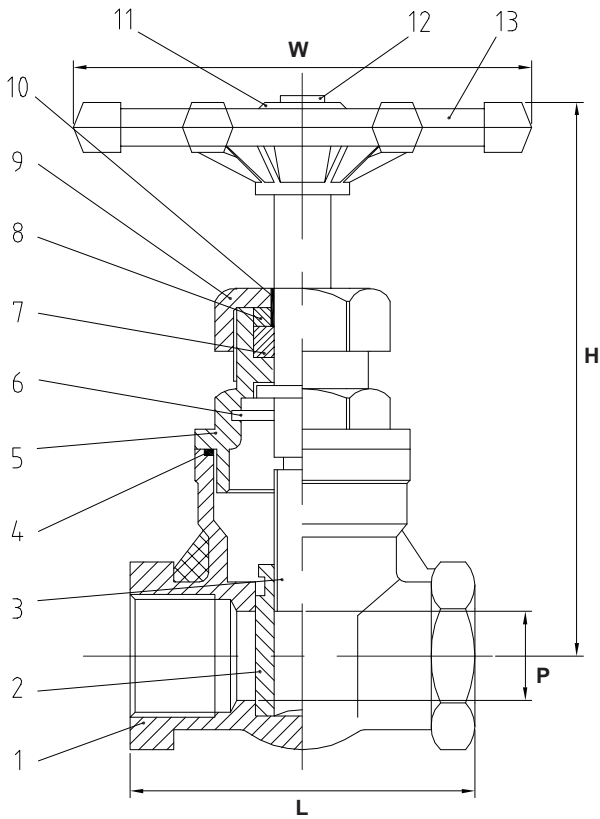
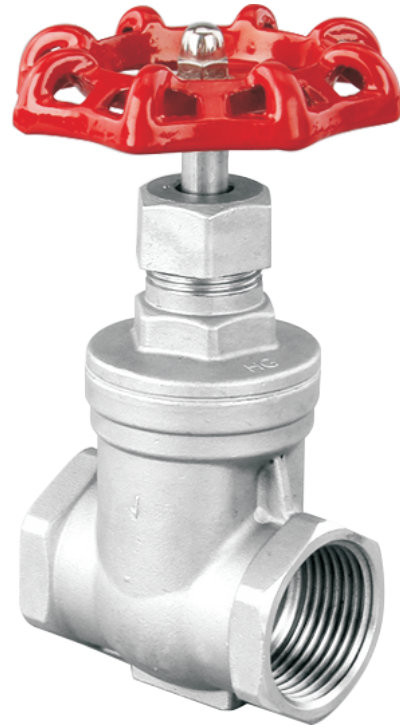

**Dimension:(mm)**

NPS	P	W	H	L
1/2"	15	63	105	50
3/4"	20	63	108	56
1"	25	63	130	60
1-1/4"	32	98	145	70
1-1/2"	40	98	155	74
2"	50	98	185	84

## Main Part Material

No.	Name	Material
1	Body	SS304/316
2	Disc	SS304/316
3	Stem	SS304/316
4	Gasket	PTFE
5	Bonnet	SS304/316
6	Snap Ring	SS304/316
7	Packing	PTFE
8	Gland	AISI 304
9	Cap Nut	AISI 304
10	Washer	PTFE
11	Spin Washer	AISI 304
12	Stem Nut	AISI 304
13	Handle	CI