

3W SOLENOID CONTROLLED VALVE

Model IR-210-3W-X

The BERMAD Solenoid Controlled Valve is a hydraulically operated, diaphragm actuated control valve that opens and shuts in response to an electric signal.



- [1] BERMAD Model IR-210-3W-X opens in response to electric signal.
- [2] BERMAD Ultrasonic Water Meter
- [3] BERMAD Combination Air Valve Model IR-C10
- [4] BERMAD Vacuum Breaker
- [5] RTU

Features & Benefits

- Line Pressure Driven, Hydraulically Controlled
 - Hydraulically control Valve with Solenoid Control
 - Line pressure driven
 - Electrically controlled On/Off
 - Suitable also for remote and/or elevated systems
- Plastic Globe Hydro-Efficient Valve
 - Unobstructed flow path
 - Single moving part
 - High flow capacity
 - Highly durable, chemical and cavitation resistant
- Unitized Flexible Diaphragm and Guided Plug
 - Excellent low flow regulation performance
 - Prevents diaphragm erosion and distortion
- Fully Supported & Balanced Diaphragm
 - Requires low actuation pressure
- User-Friendly Design
 - Simple in-line inspection and service

Typical Applications

- Computerized Irrigation Systems
- Distribution Centers
- Landscape
- Low Supplied Pressure Irrigation Systems

Operation:

Line Pressure ① is applied to the Control Chamber ② through the opened 3-Way Solenoid ③. This creates superior closing force that moves the Diaphragm Assembly ④ toward a closed position. Closing the solenoid causes it to discharge pressure from the control chamber, thereby opening the valve.

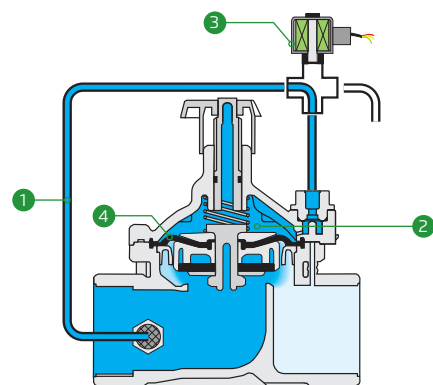

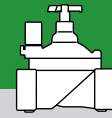

IR-210-3W-X

Technical Data

Rating:
10 bar; 145 psi
Operating Pressure Range:
0.5-10 bar; 7-145 psi

Materials:
Body, Cover and Plug:
Polyamid 6 & 30% GF
Diaphragm: NBR
Seals: NBR
Spring: Stainless Steel
Cover Bolts: Stainless Steel

Control Accessories:
Tubing and Fittings:
Plastic

Solenoid Voltage Range:
S-390 & S-400:
24 VAC, 24 VDC
S-392-T & S-402:
9-20VDC Latch
S982 & S985:
12-50 VDC Latch
Other Voltages available

Technical Specifications

Dimensions & Weights

For more details of [BERMAD 200 series](#)
Please see our full engineering page.

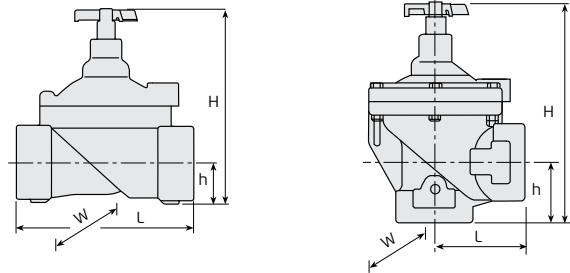

Sizes Inch ; DN	1½" ; 40		2" ; 50	
Pattern	Globe	Angle	Globe	Angle
L (mm)	160	80	170	85
H (mm)	180	190	190	210
W (mm)	125	125	125	125
h (mm)	35	40	38	60
Weight (kg)	1	0.95	1.1	0.91

Flow Properties

Sizes	Inch DN	1½" 40	1½" 40	2" 50	2" 50
Pattern		G	A	G	A
KV		37	41	47	52

Valve Flow Coefficient

$$\Delta P = \left(\frac{Q}{Kv} \right)^2$$

$Kv = m^3/h @ \Delta P \text{ of } 1 \text{ bar}$
 $Q = m^3/h$
 $\Delta P = \text{bar}$

Flow Chart

