

ARTICULO: 2284N

Trampa de vapor Termodinámica (sin filtro) Thermodynamic steam trap (without strainer)

Características	Features
<ol style="list-style-type: none"> 1. Trampa de vapor en acero inoxidable. 2. Diseño Compacto. 3. Alta durabilidad y fácil mantenimiento. 4. Aplicación: Drenaje de Líneas de Vapor 5. Extremos roscados NPT según ANSI B 2.1. <p>Condiciones de Trabajo: Máxima presión de Diseño del cuerpo: PN63. Presión máxima admisible (PMA) 63 bar a 120°C. Temperatura mínima admisible: 0°C. Temperatura máxima admisible (TMA): 425°C. Temperatura máxima de trabajo (TMO): 400°C a 43 bar r. Presión máxima de trabajo (PMO) para vapor saturado: 52 bar r. Mínima presión diferencial para buen funcionamiento: 0,25 bar. PMOB: Contrapresión máxima 80% de la presión de entrada.</p>	<ol style="list-style-type: none"> 1. <i>Stainless steel steam trap.</i> 2. <i>Compact structure.</i> 3. <i>High durability and easy maintenance.</i> 4. <i>Application: Steam pipelines drainage.</i> 5. <i>Threaded ends NPT according to ANSI B 2.1.</i> <p>Working Conditions: <i>Body design conditions: PN63.</i> <i>Maximum allowable pressure (PMA): 63 bar at 120°C.</i> <i>Minimum allowable temperature: 0°C.</i> <i>Maximum allowable temperature (TMA): 425°C.</i> <i>Maximum operating temperature (TMO): 400°C at 43 bar g.</i> <i>Maximum operating pressure (PMO) for saturated steam service: 52 bar g.</i> <i>Minimum operating differential pressure for satisfactory operation: 0,25 bar.</i> <i>PMOB: Maximum backpressure should not exceed 80% of the inlet pressure.</i></p>

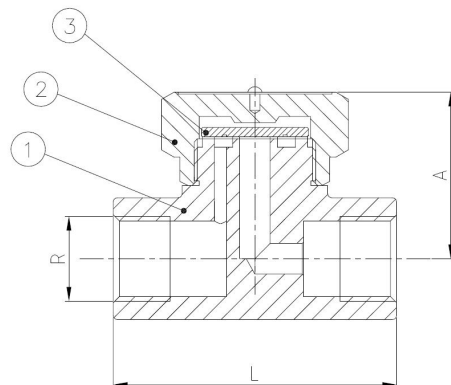

PARTES COMPONENTES – COMPONENT PARTS:

Nº	Nombre / Name	Material
1	Cuerpo / Body	Acero Inox./Stainless Steel ASTM A743 GR-CA40 (AISI 420)
2	Tapa / Cover	Acero Inoxidable/Stainless Steel CF8 (AISI 304)
3	Disco / Disc	Acero Inoxidable/Stainless Steel AISI420

DIMENSIONES – DIMENSIONS:

Ref.	Medida / Size	Rosca / Thread (R)	Dimensiones / Dimensions		Peso / Weight (Kg)
			L	A	
2284N 04	DN15	1/2" F-F	70	40	0,500
2284N 05	DN20	3/4" F-F	80	43	0,760
2284N 06	DN25	1" F-F	90	52	1,240

Condiciones límite – Limit conditions:

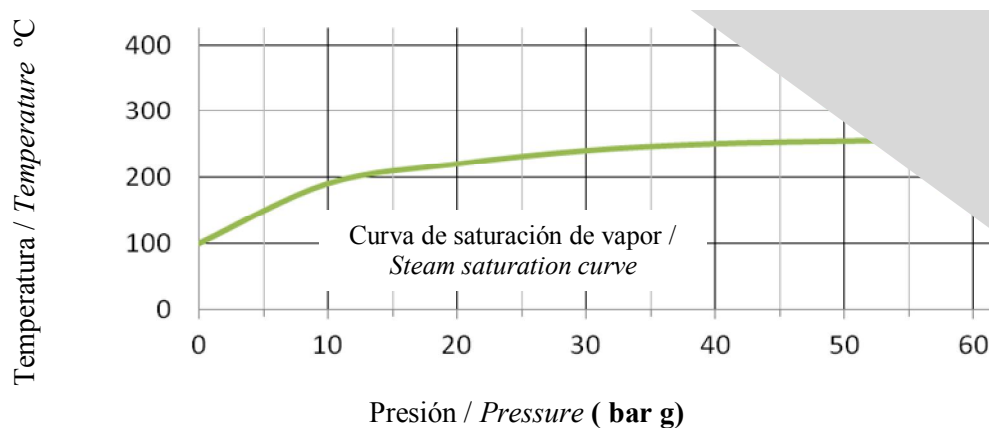

CAPACIDAD DE DESCARGA – DISCHARGE CAPACITY:

