

Air Release Valve

FIG. 9701

Specifications

- Small orifice release air under pressure during normal pipeline operation.
- The float is connected to the vent via a linkage mechanism which is capable of operating the vent under full pipeline pressure.
- FM 1344 approved.

Working Pressure and Temperature

- 300 psi rated at -10°C to 120°C.

Corrosion Protection

- Fusion bonded coating interior and exterior meet or exceed all applicable of AWWA C550 standard.

Main Dimensions

Size	Inlet Size	Outlet Size	Orifice Size
1/2"	1/2"	1/2"	1/16" or 3/32"
3/4"	3/4"	1/2"	1/16" or 3/32"
1"	1"	1/2"	1/16" or 3/32"

Schematic

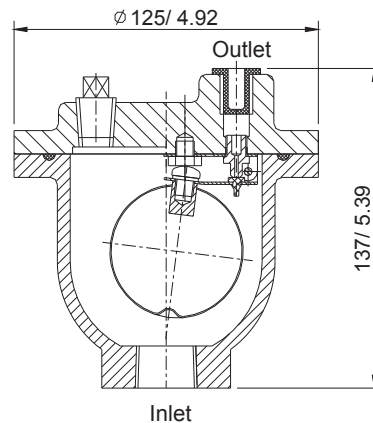
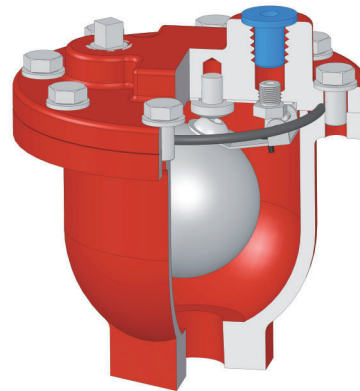

Material Specifications

Part	Material	EN Specification	ASTM Specification
Body	Ductile Iron	EN 1563, EN-GJS-450-10	A536 Grade 65-45-12
Cover	Ductile Iron	EN 1563, EN-GJS-450-10	A536 Grade 65-45-12
Lever Frame	Stainless Steel	EN 10088-3, X5CrNi18-10	A276 Type 304
Exhaust Nozzle	Stainless Steel	EN 10088-3, X5CrNi18-10	A276 Type 304
Exhaust Nozzle Seat	Rubber	EN 681, EPDM	D2000 EPDM
Float Ball	Stainless Steel	EN 10088-3, X5CrNi18-10	A276 Type 304
Ball Locator	Stainless Steel	EN 10088-3, X5CrNi18-10	A276 Type 304
Float Arm	Stainless Steel	EN 10088-3, X5CrNi18-10	A276 Type 304
Pivot Pin	Stainless Steel	EN 10088-3, X5CrNi18-10	A276 Type 304
Body/Cover Gasket	Rubber	EN 681, EPDM	D2000 EPDM

Notes

• Designs, materials and specifications shown are subject to change without notice due to the continuous development of our products.